

# TUXCO

Model HCS - 30

## Hydraulic Cylinder Servicer

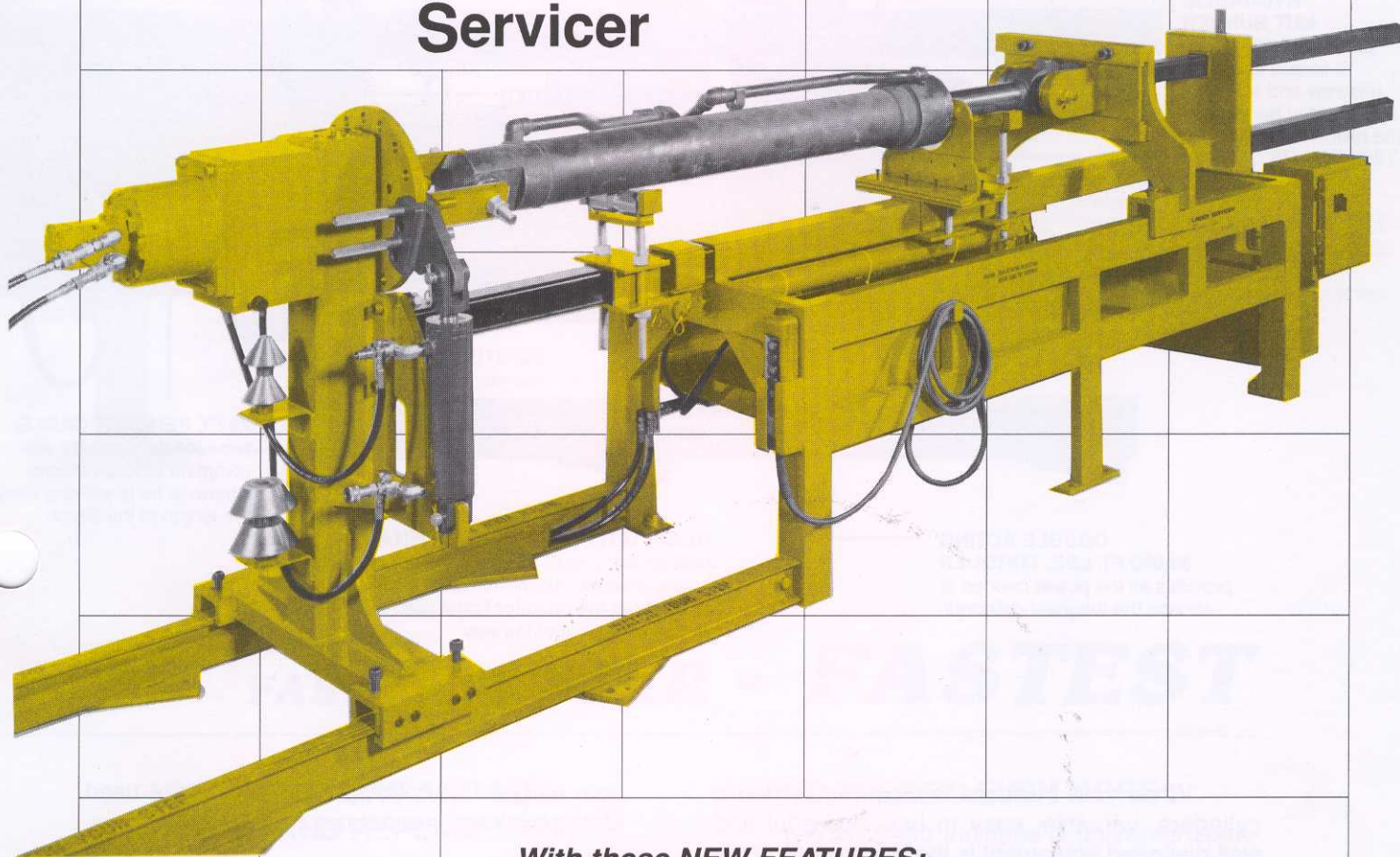

*With these NEW FEATURES:*

- 30,000 FT. LBS. OF AVAILABLE TORQUE
- HIGH SPEED HYDRAULIC NUT RUNNER
- CONVENIENT PENDANT FUNCTION CONTROL
- TIME SAVING CYLINDER MOUNTING SYSTEM

*plus all the features that have made  
TUXCO the industry leader.*

**TUXCO CORPORATION**

4300 Grove Avenue, Gurnee, Illinois 60031-2155 USA

Tel.: 708-244-2220

FAX: 708-244-7335

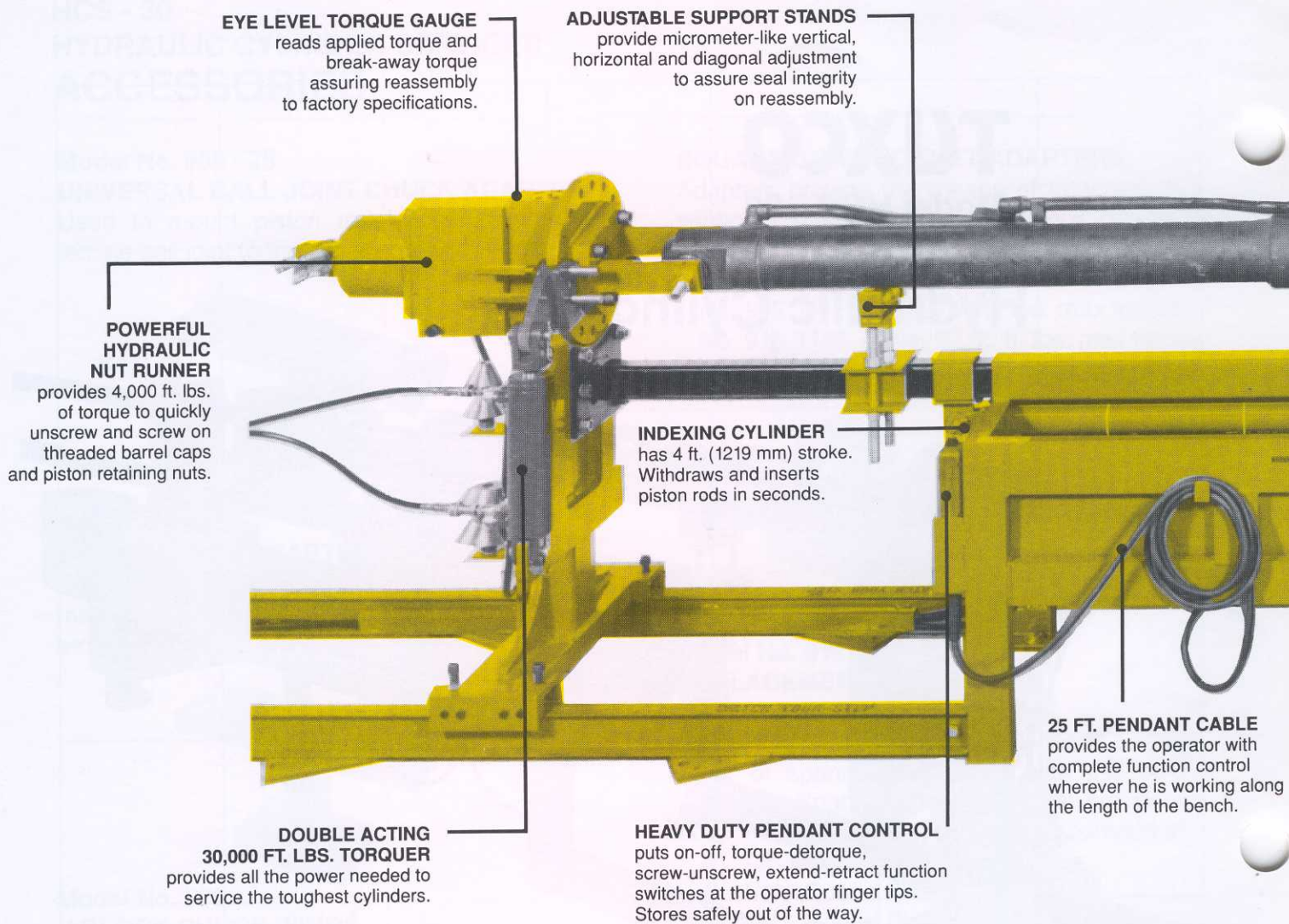

**EYE LEVEL TORQUE GAUGE**  
reads applied torque and break-away torque assuring reassembly to factory specifications.

**ADJUSTABLE SUPPORT STANDS**  
provide micrometer-like vertical, horizontal and diagonal adjustment to assure seal integrity on reassembly.

**POWERFUL HYDRAULIC NUT RUNNER**  
provides 4,000 ft. lbs. of torque to quickly unscrew and screw on threaded barrel caps and piston retaining nuts.

**INDEXING CYLINDER**  
has 4 ft. (1219 mm) stroke. Withdraws and inserts piston rods in seconds.

**DOUBLE ACTING 30,000 FT. LBS. TORQUER**  
provides all the power needed to service the toughest cylinders.

**HEAVY DUTY PENDANT CONTROL**  
puts on-off, torque-detorque, screw-unscrew, extend-retract function switches at the operator finger tips. Stores safely out of the way.

**25 FT. PENDANT CABLE**  
provides the operator with complete function control wherever he is working along the length of the bench.

When your business is repairing hydraulic cylinders, versatile, easy to use, powerful and well designed equipment is the key to getting the job done fast and profitably. And that's what TUXCO's new HCS-30 Hydraulic Cylinder Servicer is all about – one man operation and greater efficiency and more profit.

Many of the HCS-30's features have been outlined above and what those features provide is this:

### FAST SET UP

Just two sets of four conical mounting bushings handle cylinder eyes from 1.0" (25.4 mm) to 5.75" (146 mm) I.D. A third optional set handles 6.0" (152.4 mm) to 8.0" (203.2 mm) I.D.'s. No more searching through dozens of adapters. And the cone bushings are stored at

both ends of the machine where they are used. Metric bushings are not required.

### TREMENDOUS TORQUE

Hydraulic torquing device provides up to 30,000 ft. lbs. (415 kg-m) of torque to loosen threaded barrel caps and piston retaining nuts. Because the torquer is double acting it never has to be moved. And that means the HCS-30 is not only a lot easier to use, but it can be installed very close to a wall, saving up to 150 sq. ft. (13.0 sq. m) of valuable floor space.

### FAST POWERFUL ROD EXTRACTION

The HCS-30 hydraulically extracts an eight foot (2438.4 mm) piston rod in less than one minute. And there are tons of force available to handle heavy, tough rods. Rod insertion is even faster.

**CONICAL MOUNTING BUSHINGS**  
fit a wide range of eye bushings  
and provide speedy set ups  
that add to profits.

**EASILY ADJUSTABLE TAILSTOCK**  
speeds mounting of cylinders  
from one to twenty feet  
in extended length.

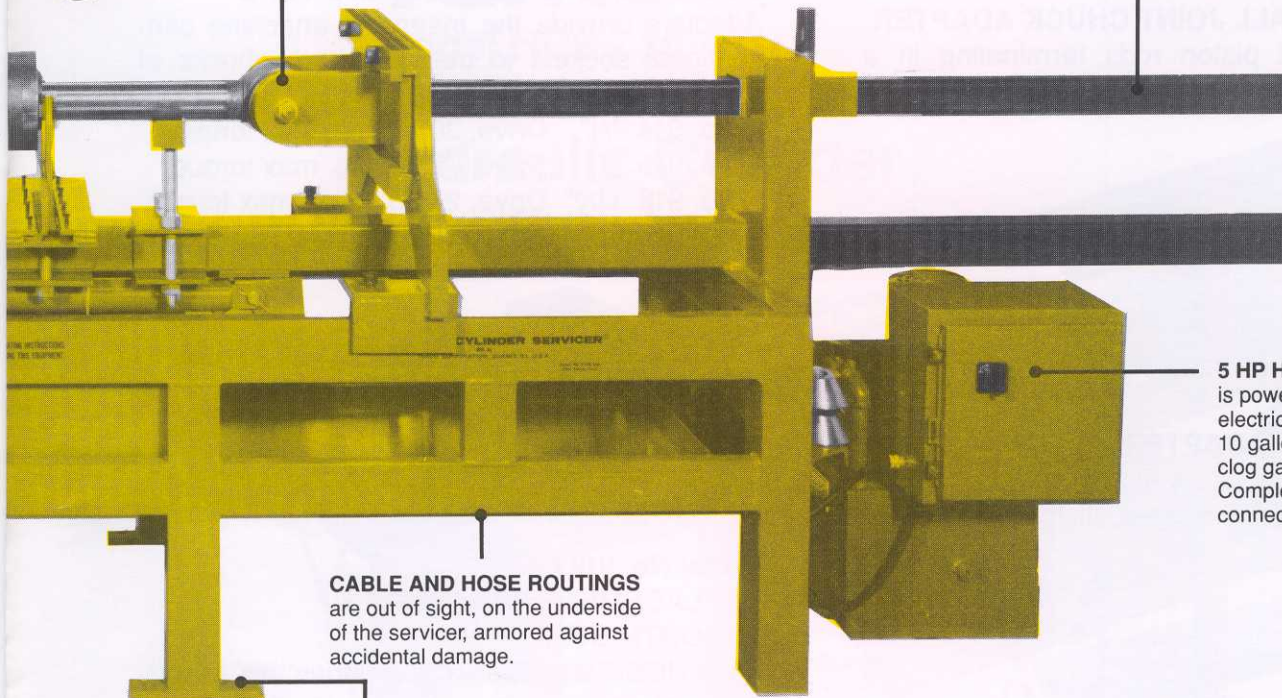

**5 HP HYDRAULIC POWER UNIT**  
is powered by an all voltage  
electric motor. The unit has a  
10 gallon tank, sight gauge, filter,  
clog gauge and solenoid controls.  
Completely wired ready for  
connection to your power system.

**CABLE AND HOSE ROUTINGS**  
are out of sight, on the underside  
of the servicer, armored against  
accidental damage.

**FLOOR MOUNTING HARDWARE**  
Installation is made easily by  
detailed instructions. Floor  
anchors and anchor tool  
are included.

## **FAST - FASTER - FASTEST**

### **HIGH SPEED CAP AND NUT REMOVAL AND REPLACEMENT**

The HCS-30 has a hydraulic, geared head nut runner permanently mounted to the headstock chuck. At the push of a button, it provides up to 4000 ft. lbs. (553 kg-m) of torque at 6 r.p.m.

### **NEW CONTROLS PREVENT LOST MOTION**

All functions are controlled by pendant mounted switches. On-off, extend-retract, torque-detorque and screw-unscrew functions are always at the operators finger tips. Special circuitry permits micro-jogging. When not in use pendant and cable have convenient storage places.

### **AND THERE'S EVEN MORE . . .**

The HCS-30 includes a universal spanner. You won't need conventional spanner wrenches. It also includes a universal high torque wrench. You won't use expensive sockets. The unit is completely wired, you need only connect it to your electric service. We even include the floor anchors, anchoring tool and Allen wrenches that are required. You'll be up and running quickly.

Specifications subject to change without notice.

