

TUXCO

Model HCS - 25 - LS

Hydraulic Cylinder Servicer

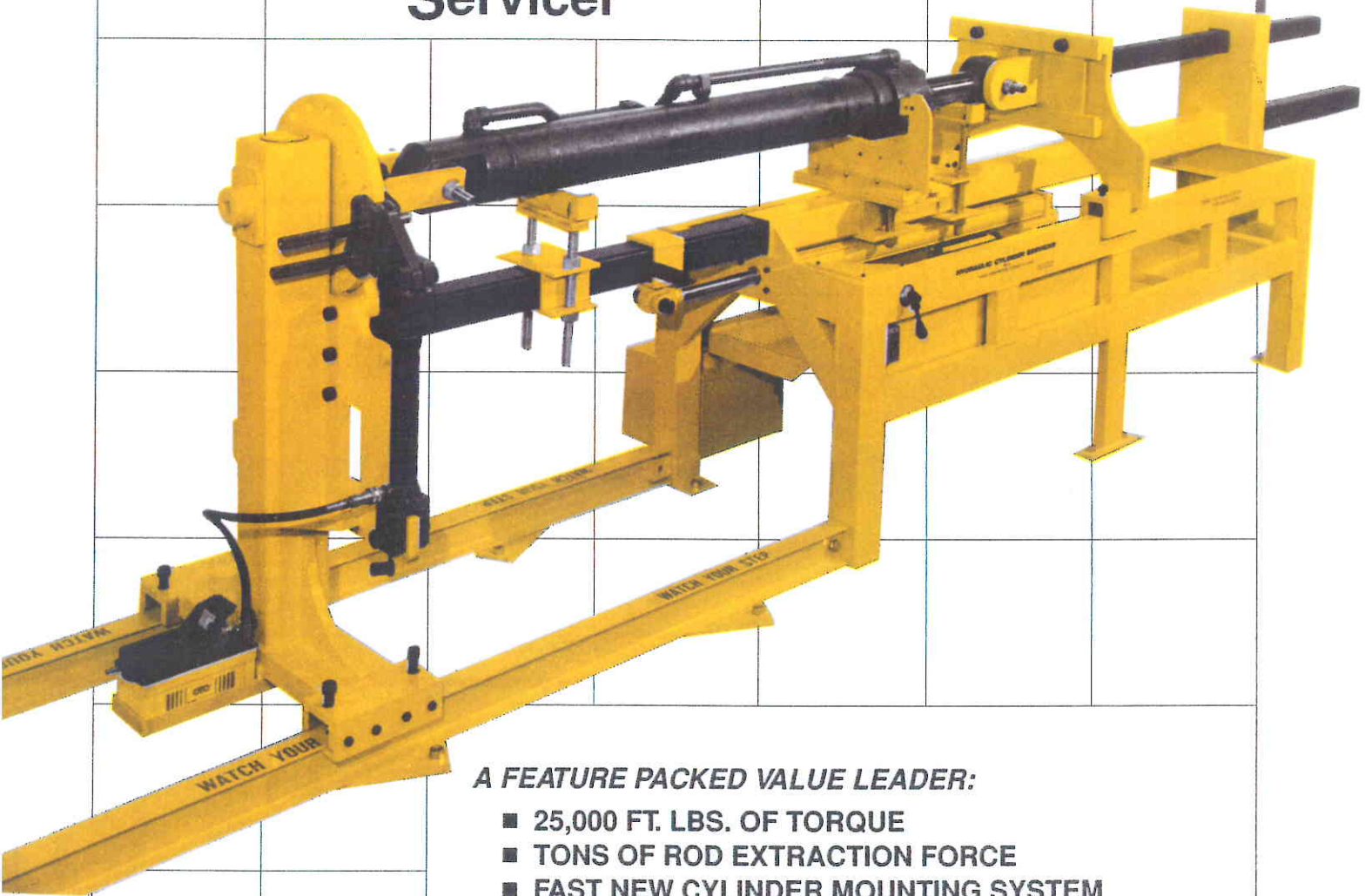

A FEATURE PACKED VALUE LEADER:

- 25,000 FT. LBS. OF TORQUE
- TONS OF ROD EXTRACTION FORCE
- FAST NEW CYLINDER MOUNTING SYSTEM

*plus all the features that have made
TUXCO the industry leader.*

NEW AREA
CODE
847

TUXCO CORPORATION

4300 Grove Avenue, Gurnee, Illinois 60031-2155 USA

Tel.: 708-244-2220

FAX: 708-244-7335

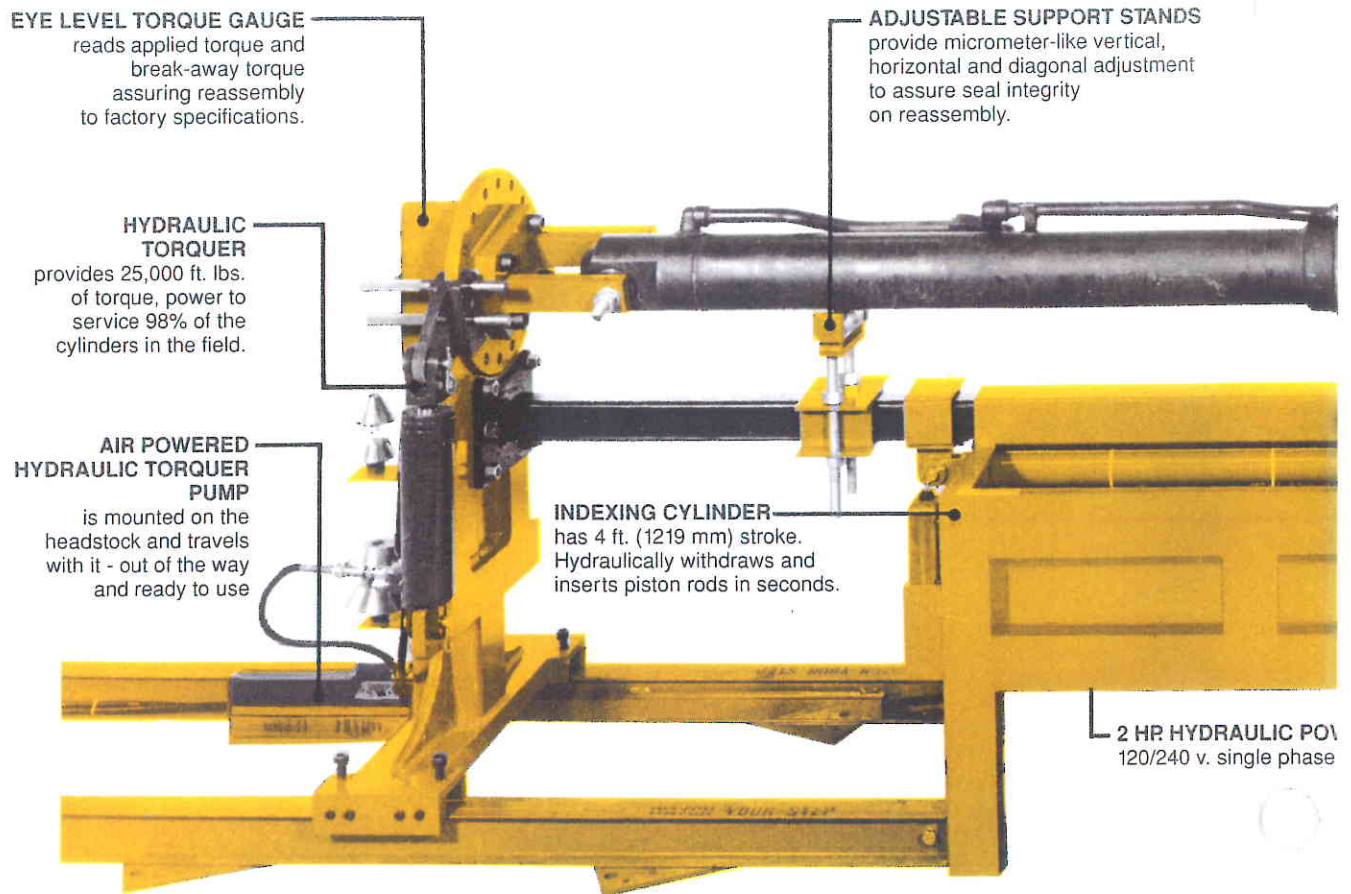

When your business is repairing hydraulic cylinders, versatile, easy to use, powerful and well designed equipment is the key to getting the job done fast and profitably. That's what TUXCO's HCS-25-LS provides - one man operation, greater efficiency and more profit.

Many of the HCS-25-LS features have been outlined above and what those features provide is this:

FAST SET UP

Just two sets of four conical mounting bushings handle cylinder eyes from 1.0" (25.4 mm) to 5.75" (146 mm) I.D. A third optional set handles 6.0" (152.4 mm) to 8.0" (203.2 mm) I.D.'s. No more searching through dozens of

adapters. And the cone bushings are stored at both ends of the machine where they are used. Metric bushings are not required.

PLENTY OF TORQUE

Because cylinders are mounted on their centerline, the HCS-25-LS's 25,000 ft. lbs. of hydraulic torque are available to loosen and tighten tough threaded barrel caps as well as piston retaining nuts.

FAST POWERFUL ROD EXTRACTION

The HCS-25-LS hydraulically extracts an eight foot (2438.4 mm) piston rod in less than 90 seconds. And there are tons of force available to handle heavy, hard to handle rods.

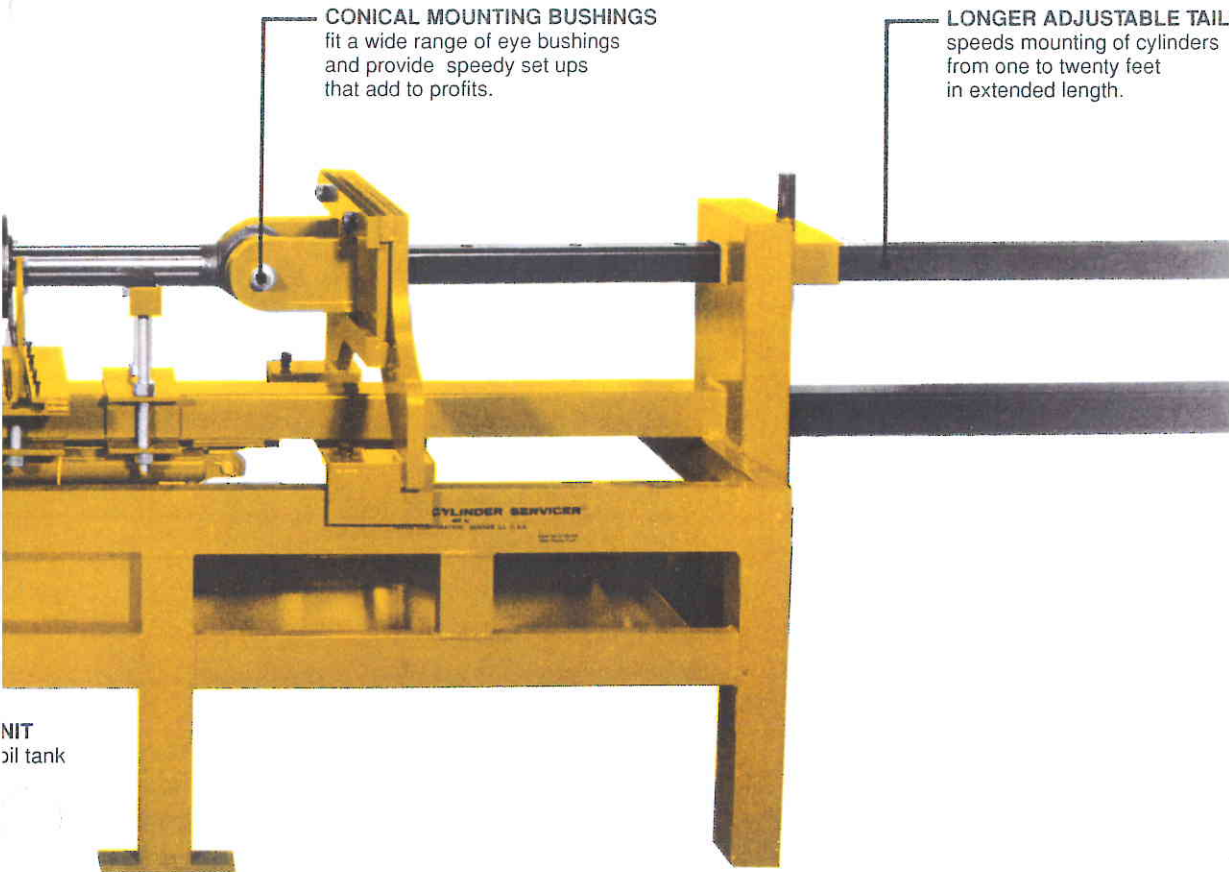

CONICAL MOUNTING BUSHINGS
fit a wide range of eye bushings
and provide speedy set ups
that add to profits.

LONGER ADJUSTABLE TAILSTOCK
speeds mounting of cylinders
from one to twenty feet
in extended length.

CYLINDER SERVICER
MODEL 25-LS

MADE IN U.S.A.

1987

NIT
oil tank

PLUS MANY MORE VALUE PACKED FEATURES

CONVENIENT CONTROLS

On - off switch and indexing cylinder control valve are located on the front of the bench at the operators finger tips. The torquing control is located at the headstock where it is convenient to the operator.

KEEPS YOUR SHOP CLEAN

Portable oil basin, bench oil pan, and splash guards helps to keep oil off the floor. A tool support grid in the oil pan keeps parts and tools high and dry.

AND THERE'S EVEN MORE . . .

The HCS-25-LS includes a universal spanner. You won't need conventional spanner wrenches. It also includes a universal high torque wrench. You won't use expensive sockets. The unit is completely wired. You need only connect it to your electric service. We even include the floor anchors, anchoring tool and Allen wrenches that are required. You'll be up and running quickly.

Specifications subject to change without notice.

HCS - 25 - LS HYDRAULIC CYLINDER SERVICER ACCESSORIES

Model No. 906 - 25

UNIVERSAL BALL JOINT CHUCK ADAPTER

Used to mount piston rods terminating in a female ball joint to the servicer T-slot chuck.



Model No. 908

BLANK CHUCK ADAPTER

Similar to 906 but with a blank face that can be machined to accept flanged lift truck cylinders, etc. For headstock order No. 908. For tailstock order No. 908-25.



Model No. 909

V-BLOCK CHUCK WINGS

For mounting cylinders in Servicer chucks when the cylinder or rod does not have a pin bushing. For Headstock order No. 909. For Tailstock order No. 909 - 25.

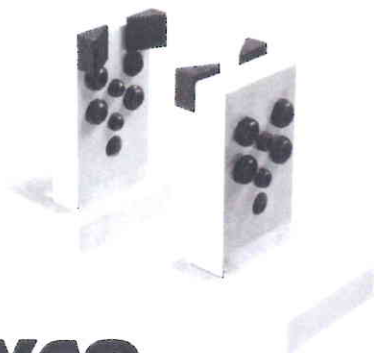

SQUARE DRIVE SOCKET ADAPTERS

Adapters provide the means of attaching conventional sockets to the headstock chucks of the HCS Series Servicers.

- No. 914 3/4" Drive, 300 ft. lbs. max torque
- No. 915 1" Drive, 750 ft. lbs. max torque
- No. 916 1 1/2" Drive, 2,000 ft. lbs. max torque
- No. 917 2 1/2" Drive, 10,000 ft. lbs. max torque



Model No. 919

REPLACEMENT SPANNER PIN ASSORTMENT

Each HCS Series Servicer includes this assortment of spanner pins used with the built-in Universal Spanner. The alloy pins are perishable. The replacement assortment consists of:

- 4 - 1/2" Square Pins (919 1/2 S)
- 4 - 1/2" Round Pins (919 1/2 R)
- 4 - 3/8" Round Pins (919 3/8 R)
- 4 - 1/4" Round Pins (919 1/4 R)

Model No. 965

UNIVERSAL WRENCH

Extra large Universal High Torque Wrench attaches to hex piston retaining nuts requiring 25,000 ft. lbs. of torque or less. Fits nuts from 4" to 6 1/2" across flats.

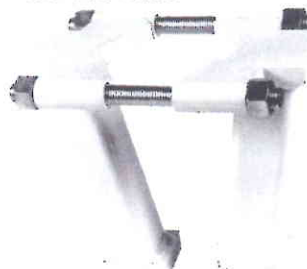

TUXCO CORPORATION

4300 Grove Avenue
Gurnee, Illinois 60031-2155
Telephone 708-244-2220
Fax 708-244-7335

